

White LED DC/DC Step-Up Converter

Features

- 2.4V to 6V Input Voltage Range
- 400mA, Internal Switch Current
- Up to 1MHz Switching Frequency
- 70µA Typical No Load Quiescent Current
- 0.1µA Typical Shutdown Current
- Internal Soft-start
- Available in a Tiny 6-Pin SOT-23 Package
- Up to 87% efficiency
- Operating Output Capacitor down to 0.1µF
- Over Voltage Protection included
- Lead Free Available (RoHS Compliant)

Applications

- Cellar Phones White LED Back Light
- PDAs, Handheld Computers
- Digital Still Cameras
- MP3 Players
- GPS Receivers

General Description

The APW7071 is a high frequency step up DC/DC converter in a small 6 leads SOT-23 package specially designed to drive white LEDs with a constant current. The device can drive up to 4 LEDs in a series from one Li-Ion cell. The APW7071 is ideal for LCD panels requiring low current and high efficiency as well as white LED applications for cellular phone back-lighting.

Package Pin Out

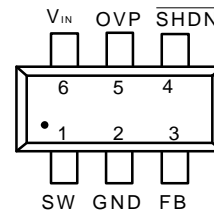

SOT-23-6 (Top View)

APW7071

Ordering and Marking Information

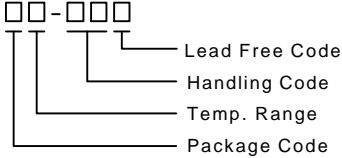
<p>APW7071 □□-□□□</p>  <p> □□ - Package Code □ - Temp. Range □□ - Handling Code □□ - Lead Free Code </p>	<p> Package Code C : SOT-23-6 Operating Junction Temp. Range E : -40 to 85°C Handling Code TU : Tube TR : Tape & Reel Lead Free Code L : Lead Free Device Blank : Original Device </p>
<p>APW7071 C : W71X</p>	<p>XXXXX - Date Code</p>

Notes: ANPEC lead-free products contain molding compounds/die attach materials and 100% matte in plate termination finish; which are fully compliant with RoHS and compatible with both SnPb and lead-free soldering operations. ANPEC lead-free products meet or exceed the lead-free requirements of IPC/JEDEC J STD-020C for MSL classification at lead-free peak reflow temperature.

ANPEC reserves the right to make changes to improve reliability or manufacturability without notice, and advise customers to obtain the latest version of relevant information to verify before placing orders.

Block Diagram

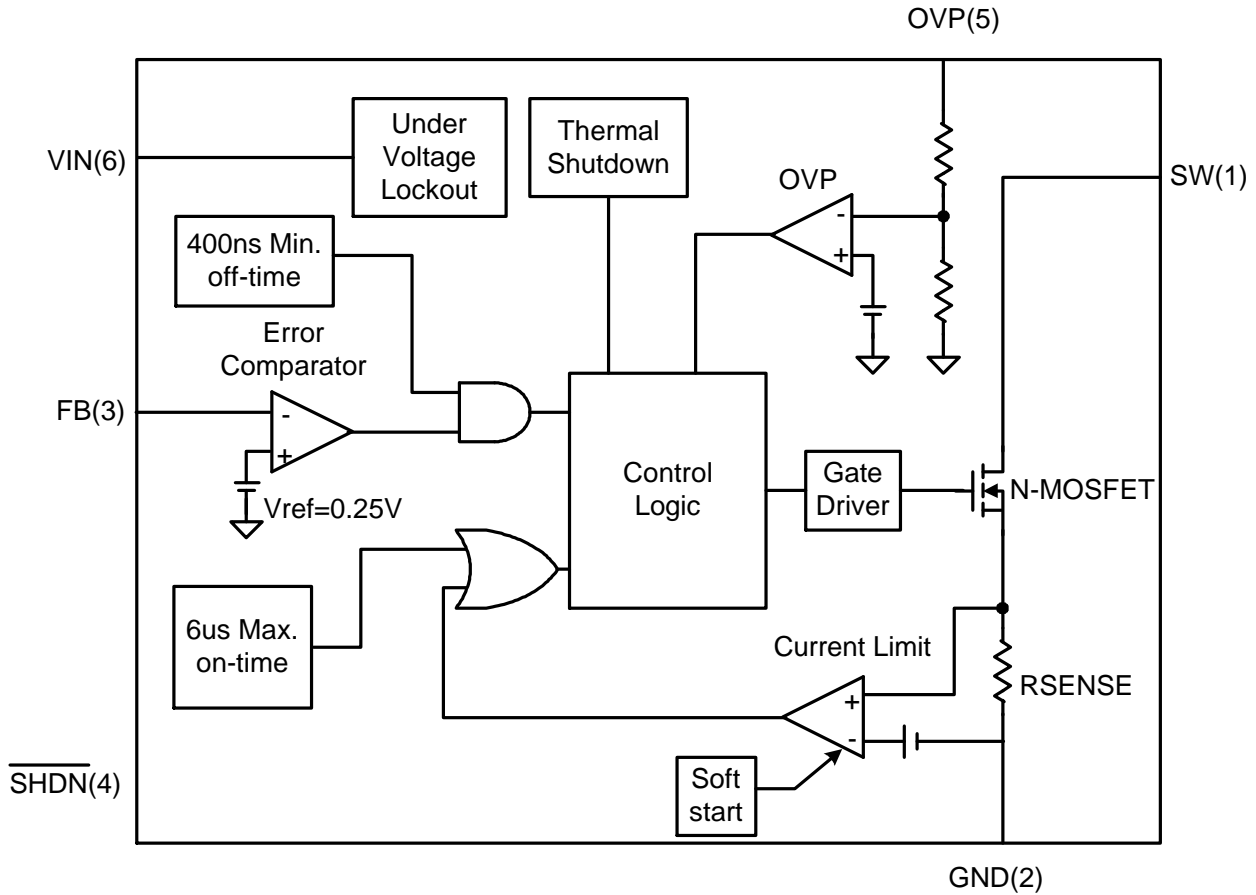

Pin Description

No	Name	Function
1	SW	Switch Pin. Connect to inductor/diode here. Minimize trace area at this pin to reduce EMI.
2	GND	Ground Pin.
3	FB	Feedback Pin. Reference voltage is 0.25V. Connect cathode of lowest LED and resistor here. Calculate resistor value according to $R_{FB} = 0.25V/I_{LED}$
4	\overline{SHDN}	Shutdown Pin. Tie to 1.3V or higher to enable device, 0.4V or less to disable.
5	OVP	Over voltage protection sense pin. Connect this pin to VOUT for over voltage protection.
6	Vin	Supply voltage Pin.

Absolute Maximum Ratings

Symbol	Parameter	Rating	Unit
V _{in}	Supply voltage	7	V
FB	Feedback Voltage	7	V
$\overline{\text{SHDN}}$	Shutdown Voltage	7	V
SW	Switch Voltage	20	V
T _J	Junction Temperature Range	150	°C
T _{STG}	Storage Temperature Range	-40 to +150	°C

Recommend Operating Conditions

Symbol	Parameter	Value			Unit
		Min.	Typ.	Max.	
V _{in}	Input supply voltage	2.4		6.0	V
V _{sw}	Switch voltage	V _{in}		18	V
L	Inductor		4.7		μH
C _{in}	Input capacitor		4.7		μF
C _{out}	Output capacitor	0.1			μF
T _a	Operating ambient temperature	-40		85	°C
T _j	Operating junction temperature	-40		125	°C

Electrical Characteristics

V_{IN}=2.4V, EN=V_{IN}, T_A=-40°C to +85°C, typical values are at T_A=+25°C (unless otherwise noted)

Symbol	Parameter	Test Condition	APW7071			Unit
			Min.	Typ.	Max.	
Supply Voltage and Current						
V _{in}	Input Voltage Range		2.4		6	V
I _q	Operating quiescent current	I _{out} =0, not switching, V _{FB} =0.3V		70	90	μA
I _{sd}	Shutdown current	$\overline{\text{SHDN}}$ =GND		0.1	1	μA
UVLO	Under-Voltage Lockout threshold		2.1		2.3	V
	Under-Voltage Lockout hysteresis			100		mV
ENABLE						
V _{IH}	$\overline{\text{SHDN}}$ high level input voltage		1.3			V
V _{IL}	$\overline{\text{SHDN}}$ low level input voltage				0.4	V
I _i	$\overline{\text{SHDN}}$ input leakage current	$\overline{\text{SHDN}}$ =GND or V _{IN}		0.1	1	μA
Power Switch and Current limit						
V _{sw}	Maximum switching voltage				20	V
t _{off}	Minimum off-time		350	400	500	ns
t _{on}	Maximum on-time		4	6	7.5	μs
R _{ds,on}	MOSFET on-resistance	V _{in} =2.4V, I _{sw} =200mA		600	1000	mΩ
	MOSFET leakage current	V _{sw} =20V		1	10	μA
ILIM	MOSFET current limit		350	400	450	mA

Electrical Characteristics (Cont.)

Symbol	Parameter	Test Condition	APW7071			Unit
			Min.	Typ.	Max.	
OUTPUT						
Vout	Adjustable output voltage range		Vin		18	V
IFB	Feedback input bias current	VFB=0.3V			1	μA
VFB	Feedback trip point voltage	2.4 VIN 6.0V	0.237	0.25	0.263	V
	OVP threshold		16	17	18	V
	OVP hysteresis		5	6	7	V

Typical Application Circuit

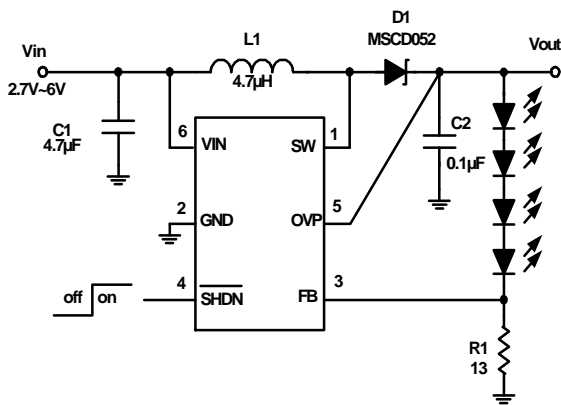

Fig.1 Typical 4LED application

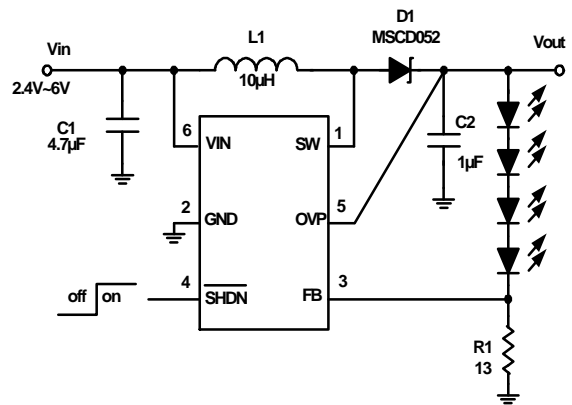
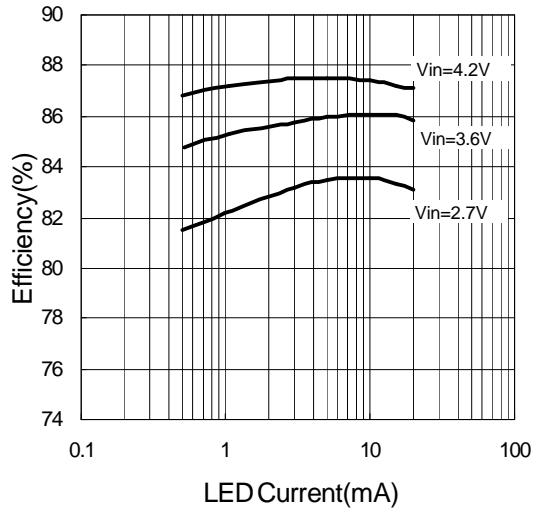

Fig.2 4LED application with lower output voltage ripple

Typical Characteristics

(Circuit of Figure 1, VIN = 3.3V, ILED = 15mA, L1 = 4.7μH, CIN = 4.7μF, COUT = 0.1μF, 4 LEDs, TA = +25°C, unless otherwise noted.)

Efficiency vs LED Current



Efficiency vs Supply Voltage

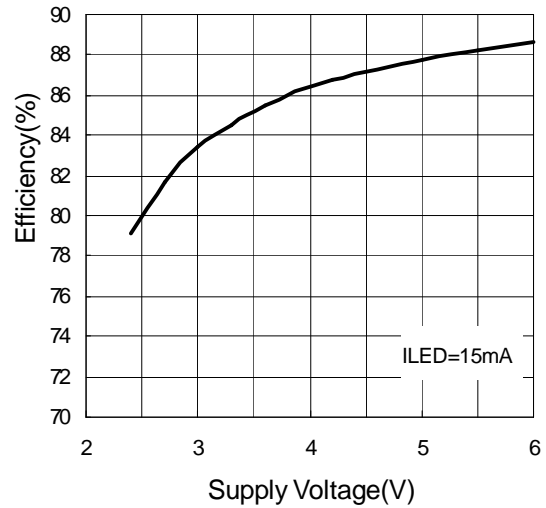

Switch Rds,on vs Supply Voltage

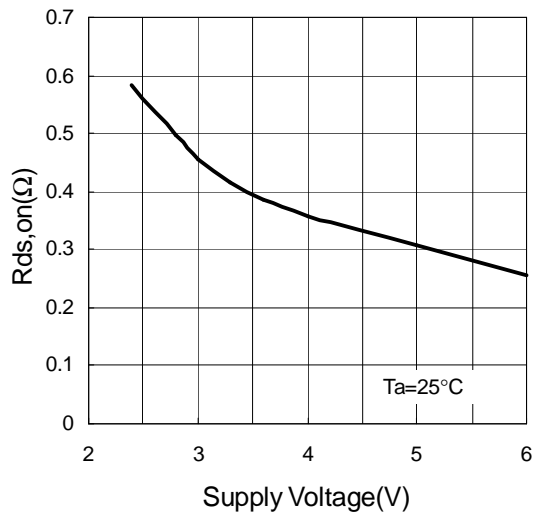

Switch Rds,on vs Temperature

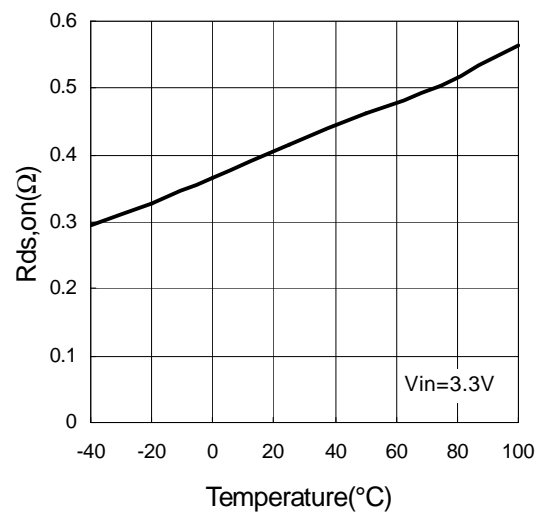

Typical Characteristics (Cont.)

Non-Switch Quiescent Current vs. Supply Voltage

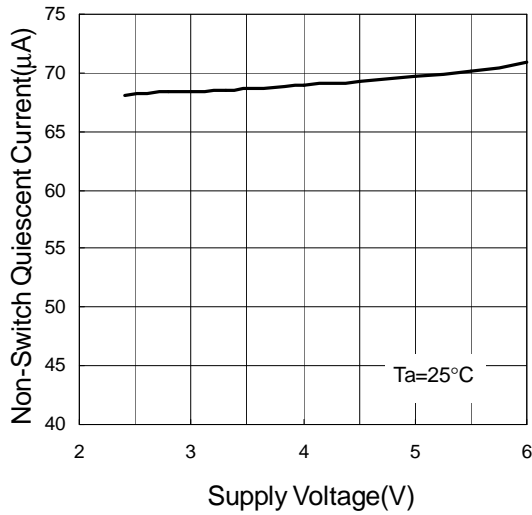

Non-Switch Quiescent Current vs. Temperature

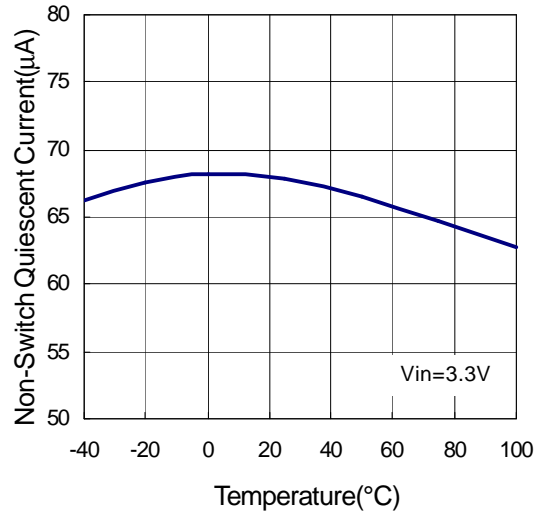

LED Current vs. Supply Voltage

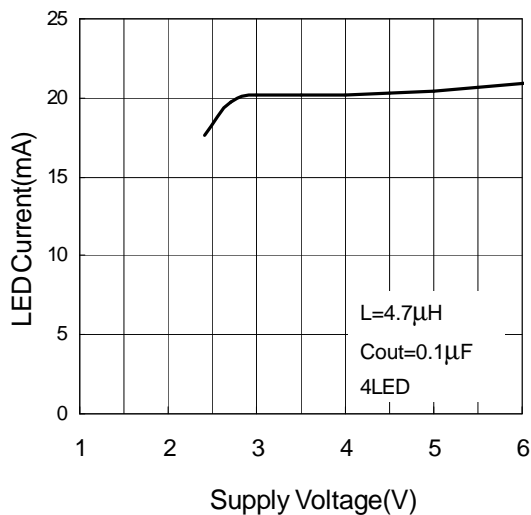

Start-up Waveform

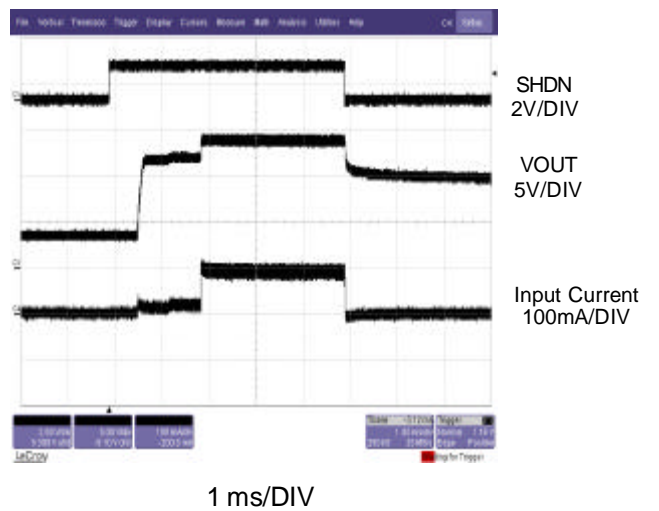

Typical Characteristics (Cont.)

OVP Waveform

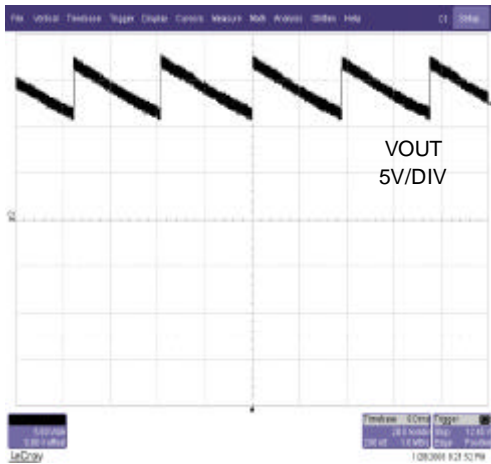

20 ms/DIV

PFM Operation

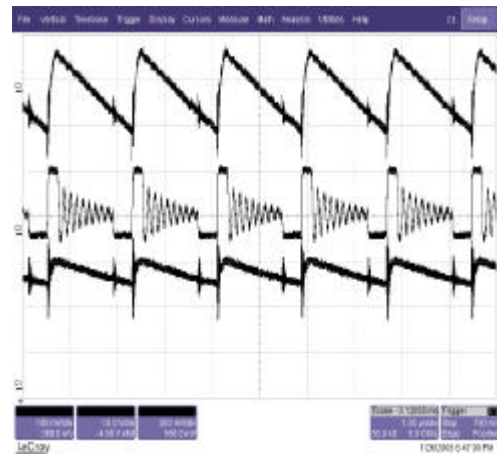

1 μ s/DIV

Burst Mode Operation

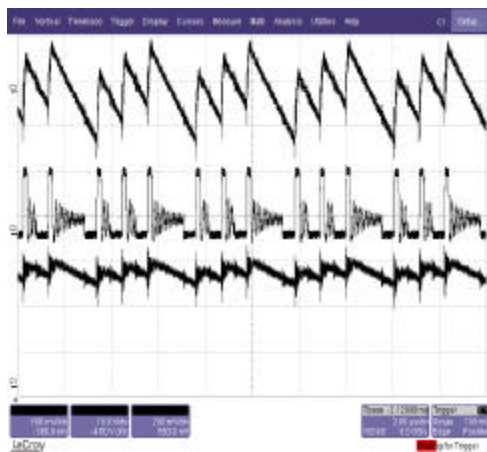

2 μ s/DIV

Function Descriptions

OPERATION

The APW7071 operates in a pulse frequency modulation (PFM) scheme with constant peak current control. The operation can be understood by referring to the block diagram of Figure 1. The converter monitors the output voltage, and if the feedback voltage falls below the reference voltage (typical 0.25V), the internal switch turns on and the inductor current ramps up. The switch turns off if the inductor current reaches the internally set peak current (typical 400mA) or maximum on-time detected. As the switch is turned off, the inductor current ramps down to zero and charge output capacitor through external Schottky diode. The switch remains off for a minimum of 400 ns (typical), or until the feedback voltage drops below the reference voltage again. The operation frequency is up to 1MHz and is determined by the output current, current limit, inductor value, input voltage and output voltage. This regulation scheme is inherently stable, allowing a wider selection range for the inductor and output capacitor.

Enable

Force SHDN pin greater than 1.3 V to enable the device works in normal operation. Pulling SHDN pin less than 0.4V to shut down reducing the shutdown current to 0.1 μ A (typical). The SHDN pin should not be left floating.

Soft Start

The APW7071 limits this inrush current by increasing the current limit at start-up.

Under Voltage Lockout

Transients during powering on or instantaneous glitches in the supply voltage can cause system damage or failure. The undervoltage lockout circuit turned the main switch off to prevent malfunction at low input voltage.

Over Voltage Protection (OVP)

OVP is integrated to prevent the output voltage increase over the maximum switching voltage rating. In some cases an LED may fail, this will result in the feedback voltage always being zero. The device will boost the output voltage higher and higher. When the output voltage exceeds the OVP threshold voltage (typical 17V), the switch turns off. The converter switch remains off until the output voltage falls below the OVP threshold voltage.

Thermal Shutdown

A thermal shutdown function is integrated to shut-down device when junction temperature exceed 160°C. If thermal shutdown detected, converter switch turn off until junction temperature falls below 120°C.

Application Information

Setup the LED current

The LED current is controlled by the reference voltage and resistor and R1 shows in Figure 1. The current through the LEDs is given by the $250\text{mV}/R1$.

Brightness control

a. By an adjustable DC voltage

Uses a DC voltage to control the feedback voltage. As the DC voltage increases, current starts flowing down R3, R2 and R1. The loop will continue to regulate the feedback voltage at 250mV. Thus the current has to decrease through the LEDs by the same amount of current as is being injected from the DC voltage source. With a VDC from 0V to 3.3V, the resistor values shown for R2 and R3 can control the LED current from 0mA to 20mA.

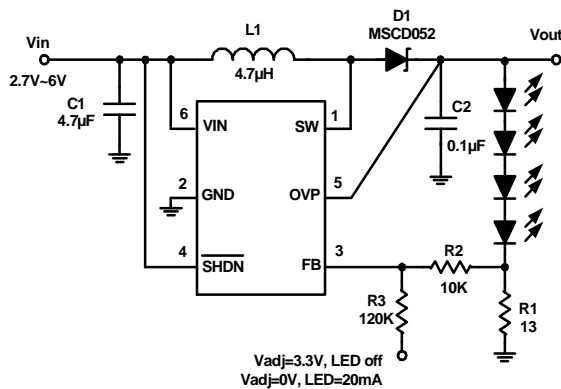

Fig. 3 Brightness Control by an adjustable DC voltage

b. By a PWM signal apply to SHDN

The PWM signal is applied to the SHDN pin of the APW7071. The LEDs will switch between full load to completely shut off. The average current through the LEDs will increase proportionally to the duty cycle of the PWM signal. Due to the soft start function, the PWM signal should be 100Hz to 300Hz.

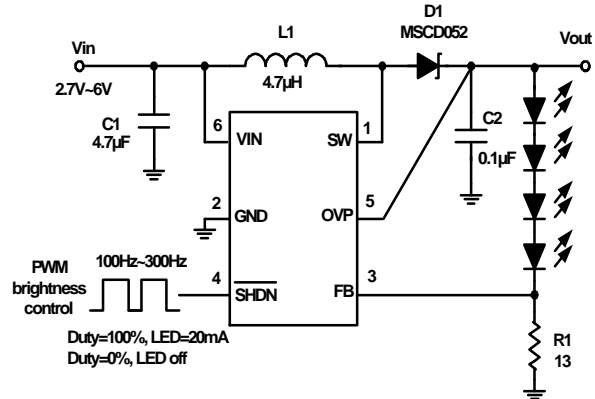

Fig. 4 Brightness Control by a PWM signal apply to SHDN

c. By a filtered PWM signal

Brightness can be achieved by a filtered PWM signal. The PWM signal above 5KHz is recommended.

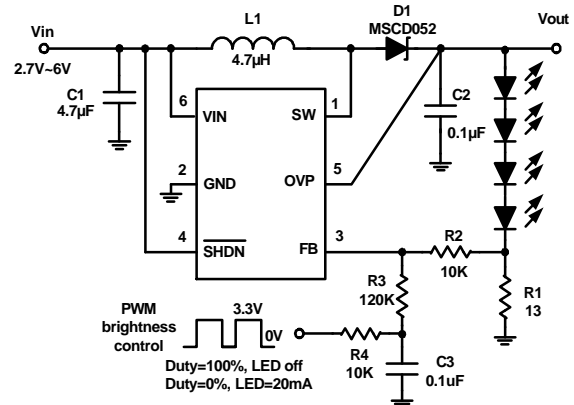

Fig. 5 Brightness Control by a filtered PWM signal

Application Information (Cont.)

Inductor selection

Since the PFM peak current control scheme is inherently stable, the inductor value does not affect the stability of the regulator. The selection of the inductor together with the nominal load current, internal set peak current, input and output voltage of the application determines the switching frequency of the converter. For the LED application, inductor values between 2.2 μ H up to 10 μ H are recommended.

Recommended inductors

Part No.	Value(μ H)	Vendor
LQH32CN4R7M23L	4.7	Murata
LQH32CN100K53L	10	Murata
SH30184R7YSB	4.7	ABC
SH3018100YSB	10	ABC

Output capacitor selection

For better output voltage filtering, a low ESR output capacitor is recommended. Ceramic capacitors have a low ESR value, but depending on the application, tantalum capacitors can be used. The selection of the output capacitor value directly influences the output voltage ripple of the converter which also influences line regulation. The larger the output voltage ripple, the larger the line regulation, which means that the LED current changes if the input voltage changes. If a certain change in LED current gives a noticeable change in LED brightness, depends on the LED manufacturer and on the application. Applications requiring good line regulation $\pm 1\%/V$ (typ) must use output capacitor values equal or larger than 1 μ F.

Recommended output capacitor

Part No.	Value	Vendor
GRM185R61C105KE44D	1.0 μ F/X5R/0603/16V	Murata
Any	0.22 μ F	Any
Any	0.1 μ F	Any

Input capacitor selection

For good input voltage filtering, low ESR ceramic capacitors are recommended. A 4.7 μ F ceramic input capacitor is sufficient for most applications. For better input voltage filtering the capacitor value can be increased.

Recommended input capacitor

Part No.	Value	Vendor
GRM188R60J475KE19D	4.7 μ F/X5R/0603/6.3V	Murata
GRM219R60J106KE19D	10 μ F/X5R/0805/6.3V	Murata

Diode selection

To achieve high efficiency a Schottky diode must be used. The current rating of the diode must meet the peak current rating of the converter.

Recommended diode

Part No.	Reverse Voltage	Vendor
MSCD052	20	Zowie

Layout considerations

Typical for all switching power supplies, the layout is an important step in the design; especially at high peak currents and switching frequencies. If the layout is not carefully done, the regulator might show noise problems and duty cycle jitter. The input capacitor should be placed as close as possible to the input pin for good input voltage filtering. The inductor and diode should be placed as close as possible to the switch

Application Information (Cont.)

Layout considerations (Conts.)

pin to minimize the noise coupling into other circuits. Since the feedback pin and network is a high impedance circuit, the feedback network should be routed away from the inductor. The feedback pin and feedback network should be shielded with a ground plane or trace to minimize noise coupling into this circuit.

Package Information

SOT-23-6

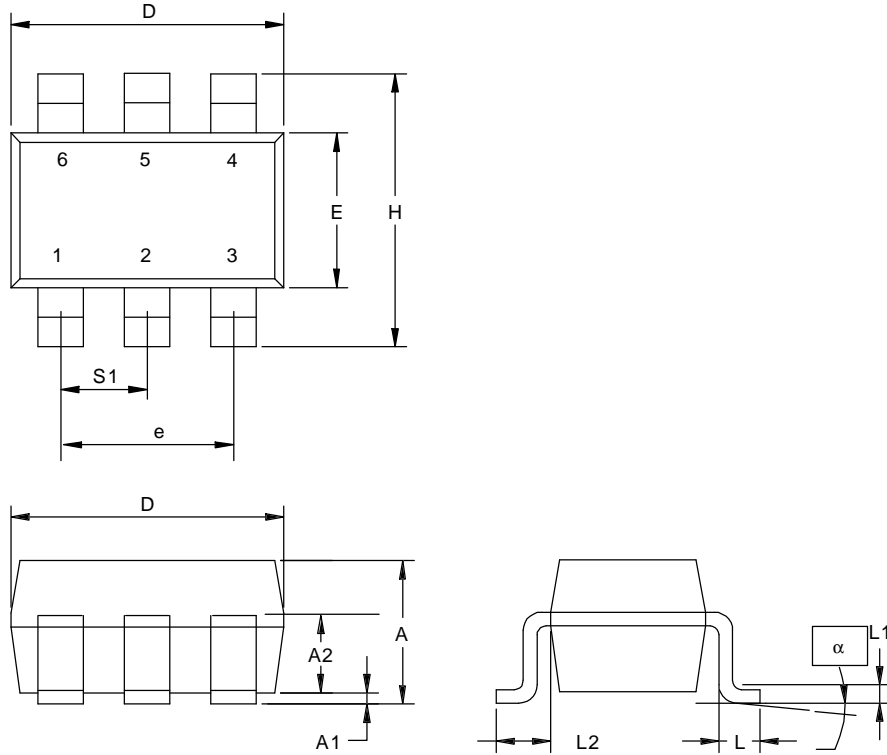

Dim	Millimeters		Inches	
	Min.	Max.	Min.	Max.
A	1.00	1.45	0.0394	0.0571
A1	0.00	0.15	0.0000	0.0591
A2	0.70	1.25	0.0276	0.0492
b	0.35	0.55	0.0138	0.0217
D	2.70	3.10	0.1063	0.1220
E	1.40	1.80	0.50551	0.0709
e	1.90 BSC		0.07480 BSC	
H	2.60	3.00	0.1024	0.1181
L	0.30	-	0.0118	-
L1	0.08	0.25	0.0031	0.0098
L2	0.60 REF		0.024 REF	
α	0°	10°	0°	10°
S1	0.85	1.05	0.0335	0.0413

Physical Specifications

Terminal Material	Solder-Plated Copper (Solder Material : 90/10 or 63/37 SnPb)
Lead Solderability	Meets EIA Specification RSI86-91, ANSI/J-STD-002 Category 3.

Reflow Condition (IR/Convection or VPR Reflow)

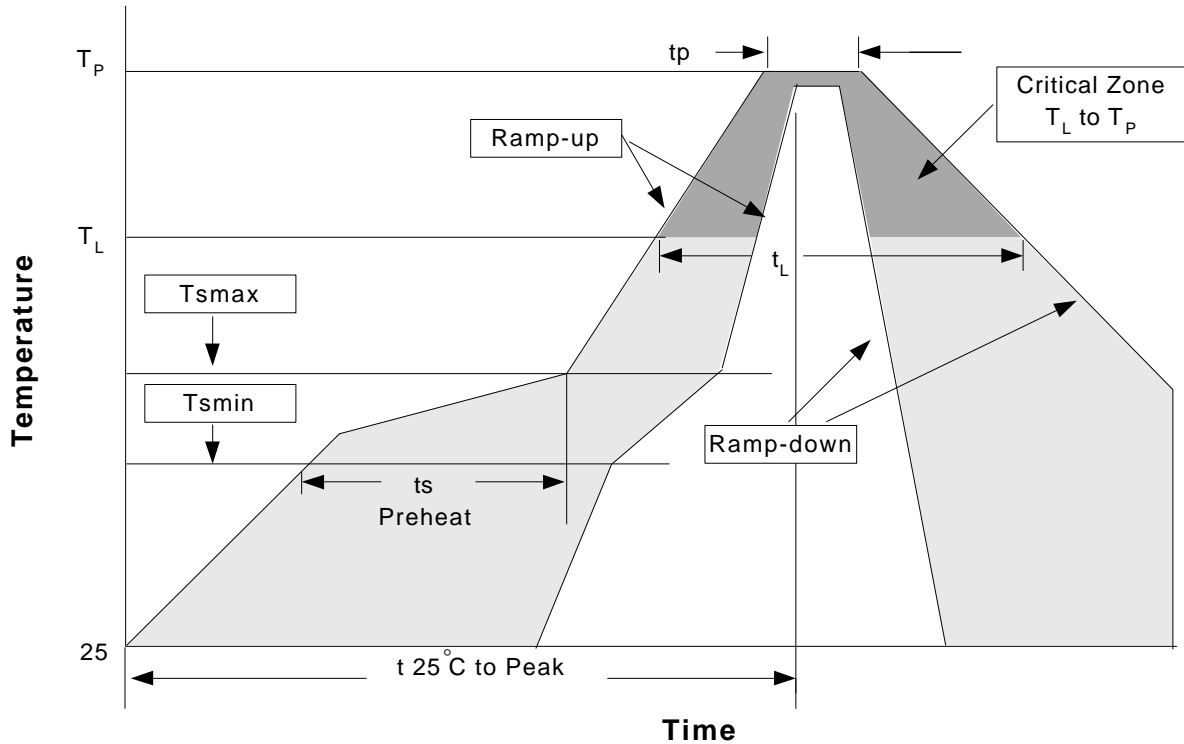

Classification Reflow Profiles

Profile Feature	Sn-Pb Eutectic Assembly	Pb-Free Assembly
Average ramp-up rate (T_L to T_P)	3°C/second max.	3°C/second max.
Preheat		
- Temperature Min (T_{smin})	100°C	150°C
- Temperature Max (T_{smax})	150°C	200°C
- Time (min to max) (t_s)	60-120 seconds	60-180 seconds
Time maintained above:		
- Temperature (T_L)	183°C	217°C
- Time (t_L)	60-150 seconds	60-150 seconds
Peak/Classification Temperature (T_p)	See table 1	See table 2
Time within 5°C of actual Peak Temperature (t_p)	10-30 seconds	20-40 seconds
Ramp-down Rate	6°C/second max.	6°C/second max.
Time 25°C to Peak Temperature	6 minutes max.	8 minutes max.

Notes: All temperatures refer to topside of the package .Measured on the body surface.

Classification Reflow Profiles(Cont.)

Table 1. SnPb Eutectic Process – Package Peak Reflow Temperatures

Package Thickness	Volume mm ³ <350	Volume mm ³ ≥350
<2.5 mm	240 +0/-5°C	225 +0/-5°C
≥2.5 mm	225 +0/-5°C	225 +0/-5°C

Table 2. Pb-free Process – Package Classification Reflow Temperatures

Package Thickness	Volume mm ³ <350	Volume mm ³ 350-2000	Volume mm ³ >2000
<1.6 mm	260 +0°C*	260 +0°C*	260 +0°C*
1.6 mm – 2.5 mm	260 +0°C*	250 +0°C*	245 +0°C*
≥2.5 mm	250 +0°C*	245 +0°C*	245 +0°C*

*Tolerance: The device manufacturer/supplier **shall** assure process compatibility up to and including the stated classification temperature (this means Peak reflow temperature +0°C. For example 260°C+0°C) at the rated MSL level.

Reliability test program

Test item	Method	Description
SOLDERABILITY	MIL-STD-883D-2003	245°C , 5 SEC
HOLT	MIL-STD-883D-1005.7	1000 Hrs Bias @ 125 °C
PCT	JESD-22-B, A102	168 Hrs, 100 % RH , 121°C
TST	MIL-STD-883D-1011.9	-65°C ~ 150°C, 200 Cycles
ESD	MIL-STD-883D-3015.7	VHBM > 2KV, VMM > 200V
Latch-Up	JESD 78	10ms , I _{tr} > 100mA

Carrier Tape

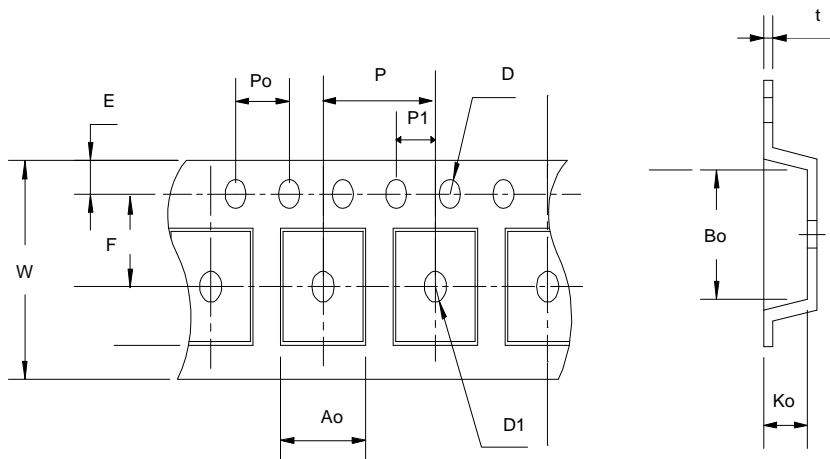

Carrier Tape(Cont.)

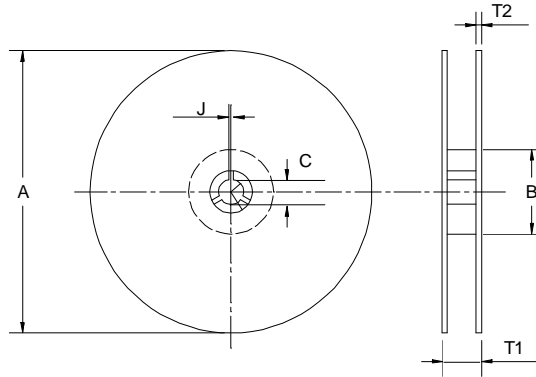

Application	A	B	C	J	T1	T2	W	P	E
SOT-23-5/6	178 ±1	72 ± 1.0	13.0 + 0.2	2.5 ± 0.15	8.4 ± 2	1.5 ± 0.3	8.0 ± 0.3	4 ± 0.1	1.75 ± 0.1
	F	D	D1	Po	P1	Ao	Bo	Ko	t
	3.5 ± 0.05	1.5 ± 0.1	1.5 ± 0.1	4.0 ± 0.1	2.0 ± 0.1	3.15 ± 0.1	3.2 ± 0.1	1.4 ± 0.1	0.2 ± 0.033

(mm)

Cover Tape Dimensions

Application	Carrier Width	Cover Tape Width	Devices Per Reel
SOT- 23-5/6	8	5.3	3000

Customer Service

Anpec Electronics Corp.

Head Office :

No.6, Dusing 1st Road, SBIP,
Hsin-Chu, Taiwan, R.O.C.
Tel : 886-3-5642000
Fax : 886-3-5642050

Taipei Branch :

7F, No. 137, Lane 235, Pac Chiao Rd.,
Hsin Tien City, Taipei Hsien, Taiwan, R. O. C.
Tel : 886-2-89191368
Fax : 886-2-89191369